

RV Rental Contract

Renter(s) Information:

Renter's Full Name _____
 Full Address _____

 Phone _____
 Email _____
 Driver's License No. _____
 Exp. Date _____
 Birth Date _____
 Renter's Insurance Carrier _____
 Additional Driver's Name _____
 Driver's License No. _____
 Exp. Date _____
 Birth Date _____

Owner(s)/Property Manager Information:

Owner/Manager's Full Name **Brian Merrick**
 Full Address **3156 Wagoner St.**
Akron, OH 44319
 Phone **330-212-6612**
 Email **brianmerr@gmail.com - overlandtonight@gmail.com**
 Vehicle **Intech Luna Rover**
 VIN **7H0TL1311MN007351**
 License No **SZH 1969**

Definitions

- "Contract" means all terms and conditions found in this form, and addenda and any additional materials we provide at the time of Rental.
- "You" or "your" means the person identified as the renter on this form, any person signing the Contract, any Authorized Driver and any person or organization to whom charges are billed by us at its or the renter's direction. All persons referred to as "you" or "your" are jointly and separately bound by this Contract.
- "We," "our," "us," "I," or "my" means the private owner(s) and property manager(s) renting the Vehicle to you.
- "Web Platform" means the rental search engine that may have been used by the private owner(s) and manager(s) as an intermediary.
- "Authorized Driver" means you and any additional driver approved and listed by us on this Contract.
- "Vehicle" means the recreational vehicle identified in this Contract.
- "Loss of Use" means the loss of our right to use the Vehicle for any reason because of damage to it or loss of it during Rental. Loss of use is calculated by multiplying the number of days from the date of damage to the Vehicle until it is repaired or replaced times the nightly rental rate.

Important Disclosures

- By signing this Contract, you understand and agree that you assume all liability, whether collision, damage, or liability for the entire duration of the Rental. You agree to indemnify the Owner(s) and Property Manager(s) of the RV in any suit brought against them.
- You are covered by a web platform supplied insurance policy with a \$_____Third Party Rate Listed on Booking_____ deductible, or by a Certificate of Insurance from your insurance company, or by a commercial insurance policy from the owner. Chips in the windshield or other glass are not covered by the policy. Interior damage is not covered by the policy.
- You are **financially** responsible for all damage (both **exterior and interior**) to, or loss or theft of, the Vehicle, which includes the cost of repair or the actual cash value of the Vehicle if it is not repairable or if we elect not to repair it, **loss of use**, diminished value of Vehicle caused by damage to it or repair of it, missing equipment, connected with any damage claim whether or not you were at fault. The insurance coverage or security deposit **may** cover some or all of the damages. You will usually pay only the insurance deductible.
- You must report all accidents involving the Vehicle to us and the police within 1 hours of occurrence.
- By signing this Contract, you understand and agree that there may be optional products that you may or may not opt to add on to your Rental. You also understand and agree that there are conditional fees that may or may not be charged to you after the Rental has been completed based on usage and damages.

Terms and Conditions

1. You do hereby agree to rent the **Intech Luna Rover** VIN **7H0TL1311MN007351** from **Brian Merrick** (Owner(s)) under the following terms and conditions:
2. The rental shall be from the dates approved via the third party lease detail. (Outdoorsy, RVShare).

Renter's Initials _____

RV Rental Contract

3. The sum of the rental shall be **paid in full before pickup.**
4. You understand that the sum of this does not include a generator. A generator is available for an additional fee.
5. Propane is included in the rental. Once depleted it is your responsibility to obtain additional propane.
6. You understand that the sum of the rental includes a cleaning fee of **\$0** if returned clean or **\$150** if not returned clean.
7. You agree to pay a late return fee of **\$150** plus **\$155 per day** if you do not return the vehicle as originally agreed.
8. **Pets are not permitted in the vehicle unless otherwise authorized.** If there is evidence of a pet, you will be subject to an additional cleaning charge of **\$150** plus potential forfeiture of your entire security deposit at the manager's/owner's discretion.
9. **Smoking/vaping is not permitted in the vehicle.** If there is evidence of smoking, vaping or other strong odors, you will be subject to the additional cleaning fee of **\$350** plus potential forfeiture of your entire security deposit, at the manager's/owner's discretion.
10. The refundable security deposit for this rental is \$ Listed on third party booking.
11. No refund will be given if you prepay for a service but do not use it.
12. You agree to pick up the vehicle at the specified location at the pre-arranged time. **A late pickup fee of \$100 per hour will be charged for each hour that the vehicle is picked up late. This fee may be waived at the Owner(s)' or Property Manager(s)' sole discretion if there are extenuating circumstances.**
13. You agree to return the RV by the agreed upon time, but no later than **05:00 PM Eastern Standard Time**, on the return date stated above unless other arrangements have been made and agreed upon. **Unless arrangements have been made for a late return, a \$100 per hour late fee will be charged for each hour that the vehicle is returned later than the pre-arranged time. This fee may be waived at the Owner(s)' or Property Manager(s)' sole discretion if there are extenuating circumstances.**
14. You release the Property Manager(s) and (Owner(s) from all claims for loss of, or damage to, your personal property or that of any other person, which is left or carried in the vehicle.
15. You agree to pay us on demand for all charges due us under this Contract, including but not limited to: (a) time for the period during which you take the Vehicle; (b) there are no charges for additional drivers; (c) charges for the optional services; (d) applicable taxes if any; (e) all traffic, toll or parking violations, fines, penalties, citations, forfeitures, court costs, towing charges and other expenses involving the Vehicle assessed against us or the Vehicle; if you fail to pay a traffic or toll charge to the charging authority, you will pay us all fees owed to the charging authority; (f) **\$1500**, plus **\$0.99/mile** for every mile between the renting location and the place where the Vehicle is returned, repossessed or abandoned, plus any additional recovery expenses we incur; (g) all costs, including pre- and post-judgment attorney fees, legal fees and court costs we incur collecting payment from you or otherwise enforcing our rights under this Contract; (g) a "loss of use" fee if you return the vehicle with damage that renders it unusable or unrentable in the amount of **\$150** for each day that it is unusable or unrentable; (h) **we will not refund any charges if you return the vehicle earlier than the date or time due in.**
16. You have truthfully disclosed the identity and proper age of all drivers towing the Intech Luna Rover.
17. You agree to return the vehicle in the same condition in which it is received. This includes odor-free and clean in the interior of the RV.
18. You have read and agreed to all rental rates.
19. You are responsible for checking and maintaining all fluid levels during the rental period. **This includes checking the generator oil daily if you use the generator.**
20. Unless authorization is obtained from the manager(s) or owner(s), no repairs, modifications, replacement of parts or service shall be completed during the Rental period.
21. The manager(s)/owner(s) are **not** responsible for the loss of vacation, personal or business time, or any incidental expenses incurred by the renter, resulting from breakdown or any other delay problems. The manager(s)/owner(s) shall be responsible for completing any necessary repairs and returning the vehicle to Rental condition as promptly as possible.
22. You agree not to take the vehicle outside of the continental United States or Canada.
23. You are responsible for reporting all accidents, incidents of vandalism or theft to the police and the manager(s)/owner(s) upon discovery.
24. You agree that all driver information has been reported accurately and no unauthorized drivers shall operate the vehicle. All reported drivers must have a valid driver's license.
25. You agree that all insurance information (if applicable) provided is true and valid.
26. You agree that Vehicles shall not be driven off road or any on unpaved surface or on very rough roads of any type.
27. We may use your security deposit to pay any amounts owed to us under this Contract, which shall include replacement of fuel or LP gas, time and mileage, loss or damage to the vehicle, administrative or legal fees, fines, penalties, forfeitures, court costs, towing and storage charges and other assessed charges, unless the expenses are our fault, all costs associated with locating and recovering the vehicle, if you fail to return the vehicle as required by the terms of the Rental Contract. If the amount of your security deposit is insufficient to satisfy all amounts due, then you agree to pay all charges in excess.
28. This is a contract for Rental of the Vehicle. We may repossess the Vehicle at your expense without notice to you, if the Vehicle is abandoned or used in violation of law or this Contract. You agree to indemnify us, defend us, and hold us harmless from all claims, liability, costs and attorney fees we incur resulting from or arising out of, this Rental and your use of the Vehicle.
29. We make no warranties, express, implied or apparent, regarding the Vehicle, no warranty of merchantability and no warranty that the Vehicle is fit for a particular purpose.

Renter's Initials _____

RV Rental Contract

- 30. You must return the Vehicle to the place of pickup or another location that we specify, on the date and time specified in this Contract, and in the same condition that you received it, except for ordinary wear. Return / dropoff address: 3156 Wagoner St., Akron OH 44319
31. If the Vehicle is returned after the specified time, you remain responsible for the safety of, and any damage to, the Vehicle until we inspect it.
32. The following acts or uses of the Vehicle are prohibited and may result in forfeiture of the entire security deposit: (a) driving the Vehicle: (i) by anyone who is not an Authorized Driver, or by anyone whose driving license is suspended in any jurisdiction; (ii) by anyone under the influence of drugs or alcohol; (iii) by anyone who obtained the Vehicle or extended the Rental period by giving us false, fraudulent, or misleading information; (iv) in furtherance of any illegal purpose or under any circumstance that would constitute a violation of law other than a minor traffic citation; (v) to carry persons or property for hire; (vi) in any race, speed test or contest; (vii) to carry dangerous or hazardous items or illegal material; (viii) outside the United States and Canada; (ix) when loaded beyond its capacity, as determined by the manufacturer of the Vehicle; (x) when driven through or under an underpass or other structure without sufficient overhead or side clearance; (xi) when it is reasonable to expect you to know that further operation would damage the Vehicle; (xii) in a manner that causes damage to the Vehicle due to inadequately secured cargo; (xvi) taking the vehicle off road; or (b) failing to summon the police to any accident involving the Vehicle that caused personal injury or property damage; (c) damaging the Vehicle by your intentional, wanton, or reckless conduct; (d) damaging the Vehicle by an animal transported in the Vehicle; (e) damaging the Vehicle by sitting, standing, or lying on the roof of the Vehicle; (f) damaging the Vehicle by placing tire chains, signs, lettering or painting on the outside of the Vehicle; (g) damaging the Vehicle by placing speakers or other sound equipment on the exterior of the Vehicle; (h) taking the RV to Burning Man or EDC; (j) disabling the GPS if so equipped.
33. We may use your deposit to pay any monies owed us under this Contract.
34. You release us from all claims for, loss of, or damage to, your personal property or that of any other person, that we received, handled or stored, or that was left or carried in or on the Vehicle, whether or not the loss or damage was caused by our negligence or was otherwise our responsibility.
35. No term of this Contract can be waived or modified except by a writing that we have signed. This Contract constitutes the entire Contract between you and us. All prior representations and Contracts between you and us regarding this Rental are merged into this Contract. The laws of the state of Ohio and Summit County govern this Contract.
36. Certain items are considered non-essential convenience items. If they fail to work during a trip, no adjustments will be made to your charges. No troubleshooting by the Property Manager(s) or Owner(s) during the trip will be done for these items if there are issues. These include TVs, antennas, CD and DVD players, radios, satellite radios, GPS navigation hardware and software, fans, coffee makers, vacuum cleaners, artificial fireplaces, and microwaves.
37. A waiver by us of any breach of this Contract is not a waiver of an additional breach or waiver of the performance of your obligations under this Contract. Our acceptance of payment from you or our failure, refusal or neglect to exercise any of our rights under this Contract does not constitute a waiver of any other provision of this Contract. Unless prohibited by law, you release us from any liability for consequential, special or punitive damages in connection with this Rental or the reservation of a vehicle.
38. You will indemnify, defend, and hold us harmless from and against any claim arising out of unsafe fueling practices committed by you or your agent. If any provision of this Contract is deemed void or unenforceable, the remaining provisions are valid and enforceable.
39. You understand the specs and capabilities of the trailer and it's capacities listed on page #4. Exceeding specs, capacities, and capabilities can result in damages. Damages due to exceeding specs, capacities, and capabilities of the vehicle are the renters responsibility.

By signing below, you acknowledge that you have been given an opportunity to read this Rental Contract in its entirety, including the Terms and Conditions before being asked to sign. Your signature authorizes us to process payment from you for all charges due under this Contract, including later payment of any traffic, toll or parking violations assessed against the Vehicle.

Renter(s)' Signature: _____ Manager(s)'/Owner(s)' Signature: _____
Renter(s)' Name: _____ Manager(s)'/Owner(s)' Name: Brain Merrick
Date: _____ Date: _____

Revised 2021-03-25

Copyright © 2017-2021. All rights reserved. May not be redistributed without written permission.

Renter's Initials _____

RV Rental Contract

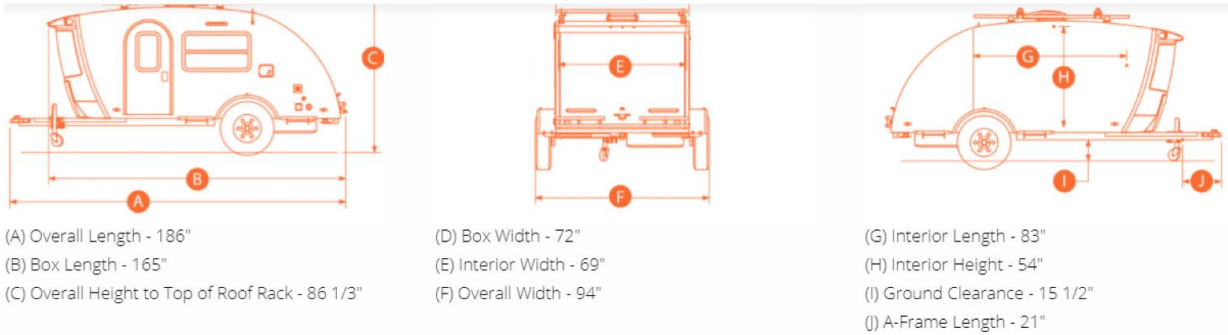

ROVER SPECIFICATIONS

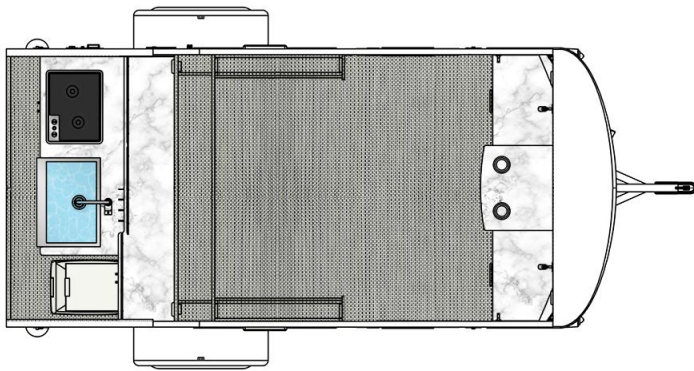

Dry Weight 1,775 - 1,850 lbs
GVWR 2,200 lbs
Net Carrying Capacity 400 - 550 lbs
Ball Height 19"
Fresh Water Tank 8.5 Gal"
Exterior
Frame All-Aluminum / All-Tube / Cage Frame
Coupler 2" Ball
Rear Receiver 2" Receiver - 100# Capacity